



KM-3030M

Manufactured by Adeka Corporation
Tokyo, Japan
Imported by OCM, Inc.
Chicago, IL.

www.adeka.com
800.999.3959
Info@adeka.com

PRODUCT DESCRIPTION:

SIZE:	30mm X 30mm (1.18" X 1.18")
PACKAGING:	10meters (33 feet per case) 30 lbs per case
PROPERTIES:	
Hardness	A33
Tensile Strength	6 MPa
Elongation	800%
Volume % Change	170% (approximately 3 times)
Vulcanization	Yes
Specific Gravity	1.18
Tested by press sheet of KM compound	
Property values are representative values and not specification values	

GENERAL DESCRIPTION:

ADEKA ULTRASEAL® KM-3030M is a chemically modified natural rubber (vulcanized) product. The manufacturing process chemically bonds a hydrophilic agent to the rubber. This permits the seal to undergo controlled expansion when exposed to moisture. This expansion capability provides a "double locking" waterstop i.e. one from rubber's natural resilience and one from expansion pressure generated when it is exposed to water. KM-3030M will expand approximately 3 times by volume.

Expansion occurs in three dimensions - width, height, and length. KM-3030M has a unique stainless steel wire mesh embedded within the material. The wire mesh eliminates unnecessary expansion in the length and width dimensions. When fastened to concrete, the wire mesh prevents "winding" action and directs the expansion.

KM-3030M has excellent durability and resistance to chemical contaminants. It can perform in a wide range of solutions such as seawater or cement water. The material does not contain any toxic substance or heavy metals and is environmentally safe.

BASIC USE:

Used in expansion joints (see installation guide for installation parameters), isolation joints and in construction / cold joints where concrete thickness exceeds 30 inches. Check concrete coverage chart before using KM-3030M.

INSTALLATION:

*** USE ONLY WHERE WALL OR SLAB THICKNESS EQUALS ONE FOOT OR GREATER.**

TYPICAL KM-3030M INSTALLATION

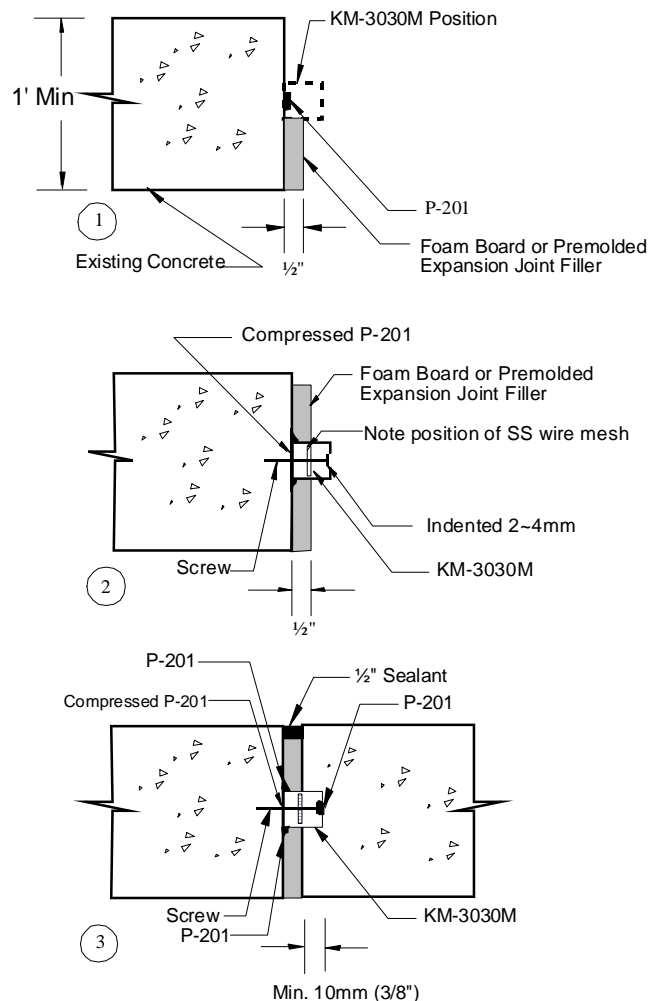

See following pages for installation procedures and product selection.

INSTALLATION CONTINUED:

METHOD 1: (Attaching waterstop to smooth concrete):

1. Surface of the concrete must be clean, dry and free from any loose debris.
2. Paint both concrete and KM-3030M with appropriate adhesive (3M-2141, Bostik 1142, Scotch Grip 1357, 3M 77 spray adhesives, 3M 92 spray adhesive or equal). Allow adhesive to become tacky- firmly press KM-3030M onto adhesive.
3. Place concrete without displacing or disturbing the position of the waterstop.

METHOD 2: Rough concrete

1. Surface of the concrete must be clean and free from any loose debris or standing water.
2. Apply bead of ADEKA ULTRASEAL® P-201. Use enough P-201 to fill any void between KM-3030M and the concrete surface)
3. Firmly press KM-3030M into the P-201 while it is still in the paste state.
4. Use a wet tool or gloved finger to remove any excess P-201. Place a nail or screw every 12~14 inches
5. Place concrete without displacing or disturbing the position of the waterstop.



OR:

Attach with nails, screws or glue then fill in rough areas with ADEKA ULTRASEAL® P-201. Inspect to insure there are no voids or gaps between KM-3030M and concrete.



* Concrete strength must be minimum 4300 PSI. Thoroughly consolidate concrete around the waterstop. Because of variables in joint filler material and concrete we recommend keyway installation as shown on following installation guide.

WHERE TO USE KM-3030M

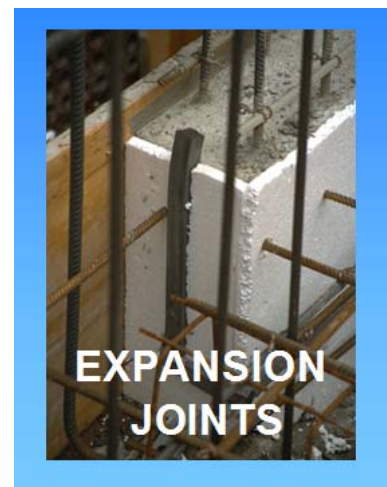

NOTE: The information contained herein is based on our present state of knowledge and is intended to provide general notes on Adeka Waterstops and their uses. Any recommendations or suggestions, which may be made, are without guarantee, since the conditions of use are beyond our control. Furthermore, nothing contained in this publication shall be construed as a recommendation for any use that may infringe patent rights. Readers are cautioned to satisfy themselves as to the suitability of such goods for the purposes intended prior to use

* Recommended ADEKA ULTRASEAL® KM-3030M Installation

For Minimum 12" Wall/Slab Expansion Joint

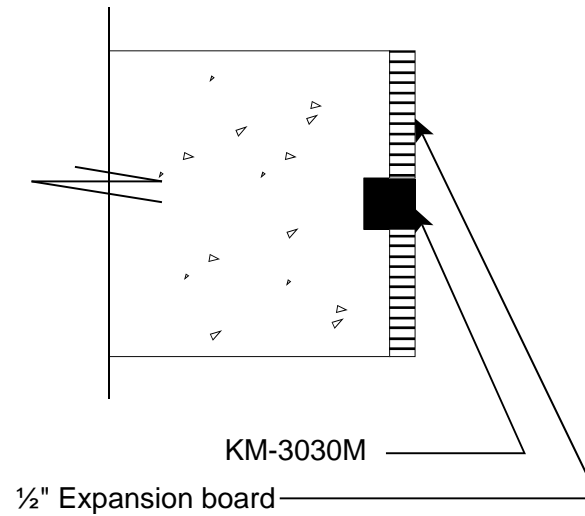
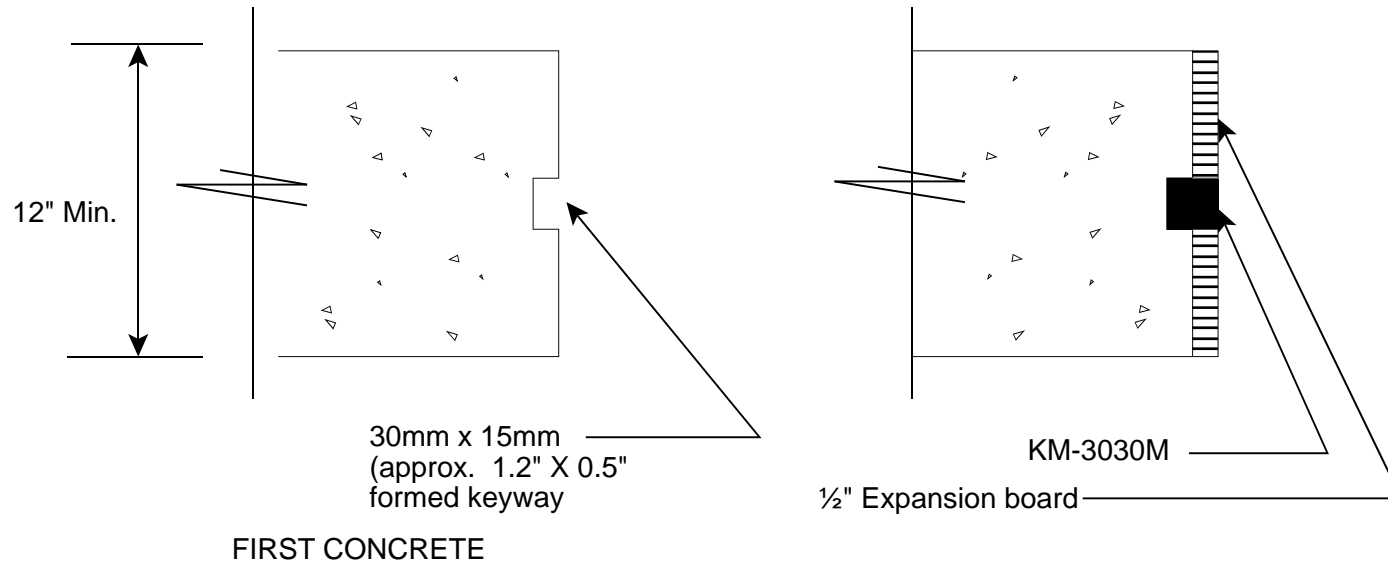

Check with your local representative for complete installation details for this procedure.

For more information call:
800.999.3959

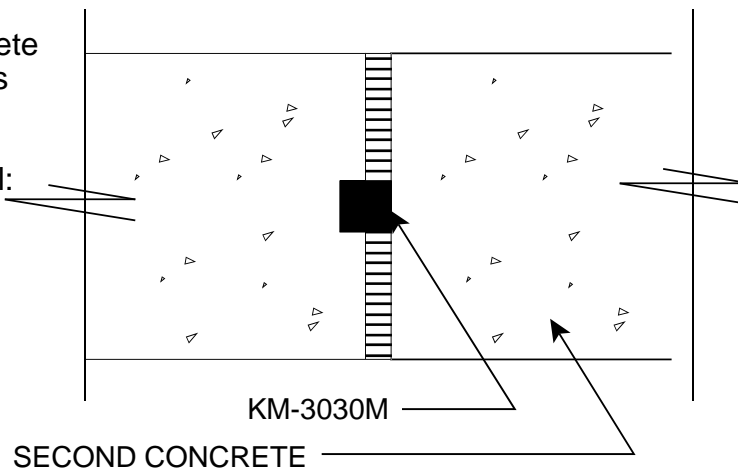

*** NOTE:** The information contained herein is based on our present state of knowledge and is intended to provide general notes on Adeka Waterstops and their uses. Any recommendations or suggestions, which may be made, are without guarantee, since the conditions of use are beyond our control. Furthermore, nothing contained in this publication shall be construed as a recommendation for any use that may infringe patent rights. Readers are cautioned to satisfy themselves as to the suitability of such goods for the purposes intended prior to use

Ideal Installation ADEKA ULTRASEAL® KM-3030M or KM-4040M

STORAGE:

Store in cool dry place. Protect from any exposure to moisture

INSTALLATION INSTRUCTIONS:

Place Concrete

1. Level Concrete
2. Prepare form for keyway - note dimensions
3. Form Keyway - Note dimensions depending on if KM-3030M or KM-4040M.

* 4. Apply $\frac{1}{4}$ " X $\frac{1}{2}$ " bead of P-201 (approximate). One 320 ml cartridge will cover approximately 12 feet at this bead size.

* Step 4 is the ideal installation procedure. P-201 will help hold the KM-3030M (KM-4040M) in place and prevent concrete fines from penetrating between the KM-3030M (KM-4040M) and the concrete. If the KM-3030M (KM-4040M) fits tightly and the concrete is smooth, P-201 may not be necessary in this area.

IMPORTANT: DO NOT ALLOW ANY GAPS BETWEEN THE CONCRETE AND THE KM-3030M or KM-4040M. USE FLAT HEAD SCREWS TO HOLD KM- FIRMLY IN PLACE WHERE EVER NECESSARY.

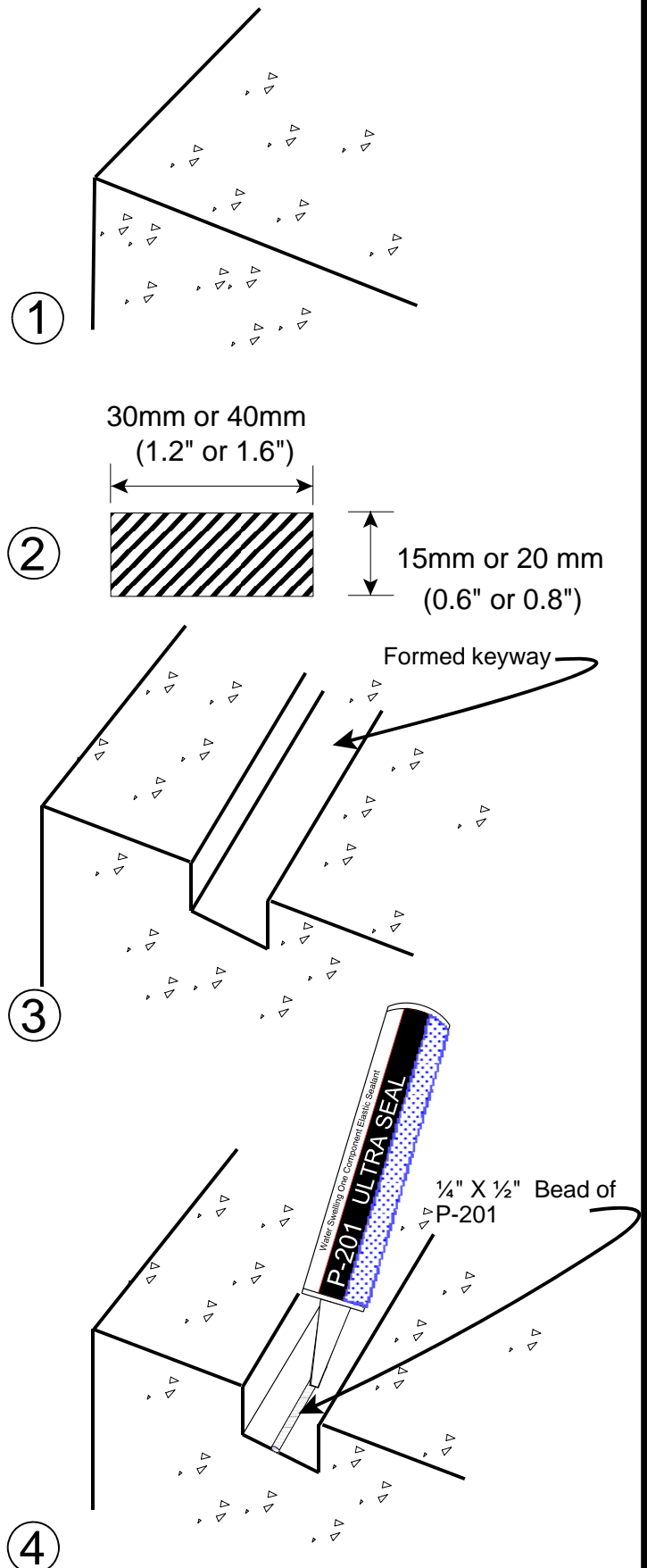

**ADEKA ULTRASEAL® KM-3030M
(KM-4040M)**

**INSTALLATION INSTRUCTIONS
CONTINUED:**

5. Note position of stainless steel mesh.

IMPORTANT - MESH MUST BE PARALLEL TO THE FACE OF THE CONCRETE AS SHOWN.

*Wire mesh shown for illustration purposes only. **THE MESH MAY NOT BE VISIBLE** in the actual product. Bend the material to determine the position of the wire mesh. When the wire mesh is parallel, it will bend easily. If it is in the wrong position, bending will be more difficult. Place the product so the wire mesh is in the position shown.*

6. Butt Joints: Apply P-201 around the perimeter of the KM-3030M (KM-4040M).

IMPORTANT - DO NOT ALLOW ANY GAPS BETWEEN SEGMENTS OF KM-3030M (KM-4040M). FOR ADDED SAFETY, APPLY SMALL BEAD OF P-201 ON TOP OF BUTT JOINT.

7. Apply small bead of P-201 at the intersection of the KM-3030M (KM-4040M) and the concrete. Apply to both sides of the concrete.

IMPORTANT - APPLYING P-201 IN THIS AREA IS ESSENTIAL. P-201 MUST COMPLETELY COVER THE INTERSECTION OF KM-3030M (KM-4040M) AND THE CONCRETE.

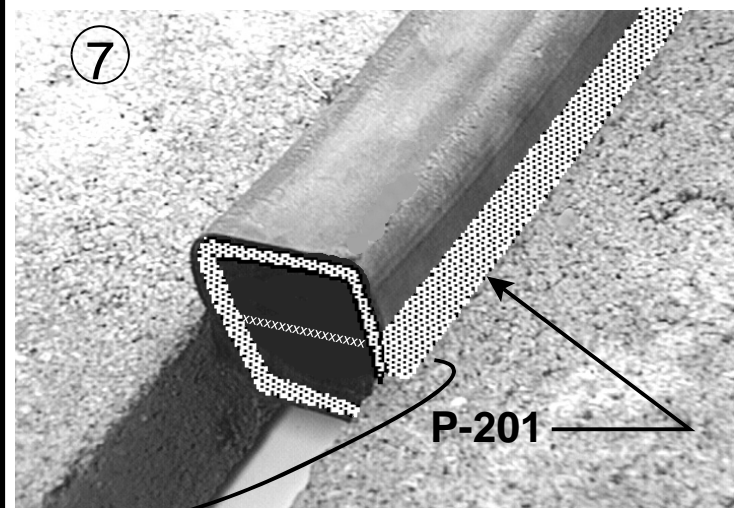
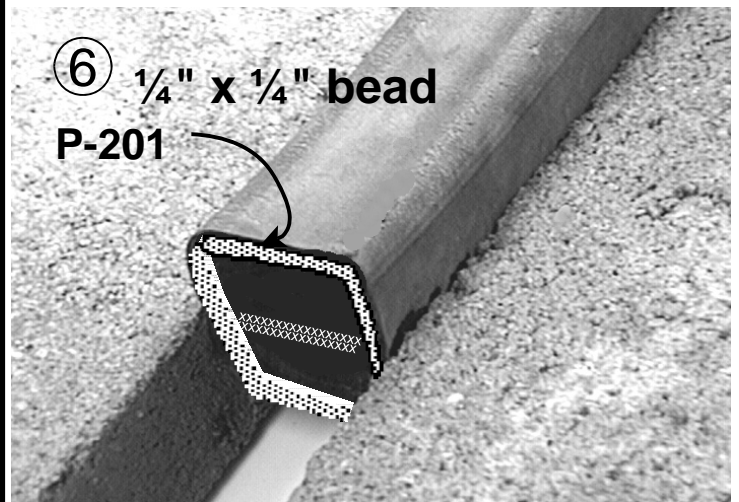
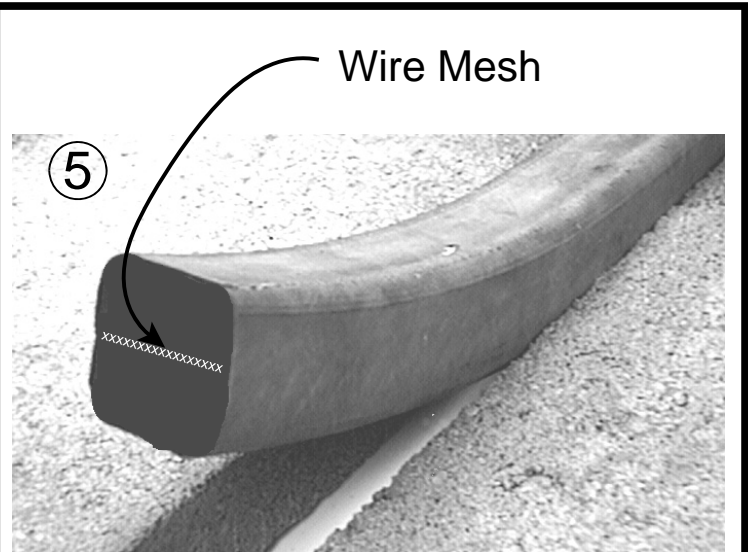
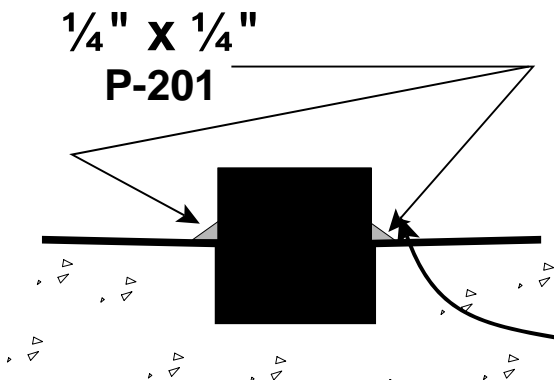

CHOOSING THE RIGHT EXPANSION JOINT PRODUCT

ADEKA ULTRASEAL® KM-3030M OR KM-4040M

IMPORTANT: "x" must always be a minimum of 10mm (0.40")

KM-3030M

Recommend "y" = 0.50" (13mm)

Minimum "x" = 0.40" (10mm)

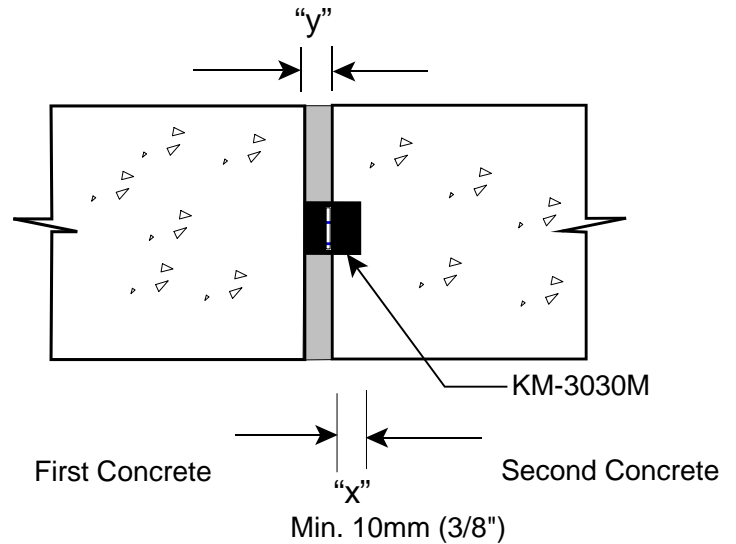

KM-4040M

Recommend "y" = 0.75" (19 mm)

Minimum "x" = 0.40" (10 mm)

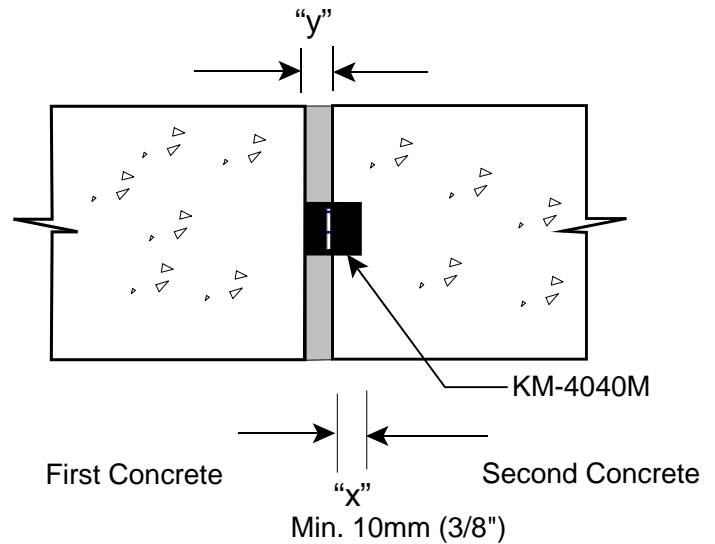

Product	Hydrostatic Head (ft)	Maximum Additional Opening Inches
KM-3003M	20	0.43
	30	0.39
	50	0.34
KM-4040M	20	0.68
	30	0.52
	50	0.46

"Maximum Additional Opening" is the best estimate of ADK. The information is based on the configuration shown above

For More Information:
CALL YOUR LOCAL ADEKA REPRESENTATIVE OR CALL (800) 999-3959